

封闭弹簧全启式安全阀

■ 系列 /

A42Y-16C、A42Y-16P、A42Y-16R、KA42Y-16、DA42Y-16C(P)、A42Y-25、A42Y-25P、A42Y-25R、KA42Y-25(P)、DA42Y-25(P)、A42Y-40、A42Y-40P、A42Y-40R、KA42Y-40、DA42Y-40(P)、A42Y-64、A42Y-64P、A42Y-64R、KA42Y-64、DA42Y-64(P)、A42Y-100、A42Y-100P、A42Y-100R、KA42Y-100、DA42Y-100(P)

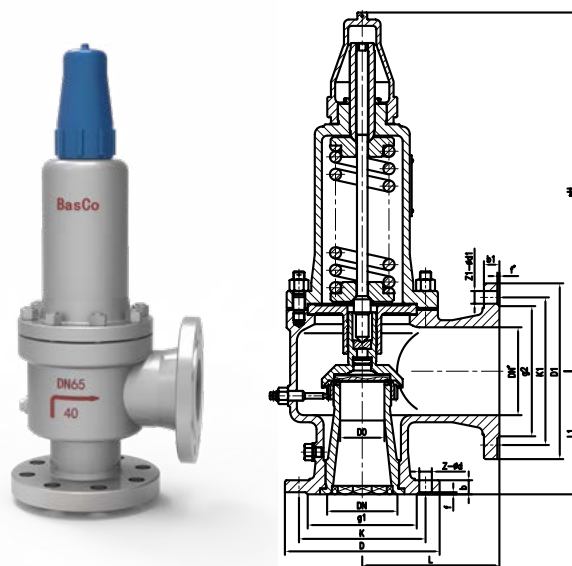

■ 用途 /

A42Y-C 型适用于工作温度 $\leq 300^{\circ}\text{C}$ 的空气、石油气、液体等介质的设备和管路上。A42Y-P 型及 A42Y-R 型适用于工作温度 $\leq 200^{\circ}\text{C}$ 有腐蚀性介质的设备或管路上，作为超压保护装置。

连接法兰标准按 JB/T.....94 系列 1。 $\geq 6.4\text{MPa}$ 按 JB/T.....94 系列 2。

■ 主要零件与材质 /

No.	零件名称	A42-C/KA42Y-C 材料	A42H-P/KA42Y-P 材料	A42Y-R 材料	DA42Y-P 材料
1	阀座	2Cr13/1Cr18Ni9Ti	ZG1Cr18Ni9Ti	ZG1Cr18Ni12Mo2Ti	ZG1Cr18Ni9Ti
2	阀体	WCB	ZG1Cr18Ni9Ti	ZG1Cr18Ni12Mo2Ti	LCB/ZG1Cr18Ni9Ti
3	调节圈	2Cr13/1Cr18Ni9Ti	1Cr18Ni9Ti	1Cr18Ni12Mo2Ti	1Cr18Ni9Ti
4	反冲盘	2Cr13/1Cr18Ni9Ti	1Cr18Ni9Ti	1Cr18Ni12Mo2Ti	1Cr18Ni9Ti
5	阀瓣	2Cr13/1Cr18Ni9Ti	1Cr18Ni9Ti	1Cr18Ni12Mo2Ti	1Cr18Ni9Ti
6	导向套	2Cr13/1Cr18Ni9Ti	1Cr18Ni9Ti	1Cr18Ni12Mo2Ti	1Cr18Ni9Ti
7	阀盖	ZG230-450	ZG1Cr18Ni9Ti	ZG1Cr18Ni12Mo2Ti	ZG1Cr18Ni9Ti
8	弹簧	SOCrVA	50CrVA 包覆氟塑料	50CrVA 包覆氟塑料	50CrVA
9	阀杆	2Cr13	1Cr18Ni9Ti/1Cr18Ni12Mo2Ti	1Cr18Ni9Ti/1Cr18Ni12Mo2Ti	1Cr18Ni9Ti
10	调整螺杆	45	2Cr13	2Cr13	2Cr13
11	保护罩	ZG200-400	ZG1Cr18Ni9Ti	ZG1Cr18Ni12Mo2Ti	ZG1Cr18Ni9Ti
	密封面材料	堆焊 Co 基硬质合金			

* 内容仅供参考，更多需求请联系我们。

■ 主要外形尺寸 /

型号	DN	D0	D	K	g	g1	b	f	f1	Z- Φd	DN'	D 1	k1	g3	g2	b1	f'	f1'	Z1- Φd1	L	L1	H
A42Y-16C A42Y-16P A42Y-16R KA42Y-16C DA42Y-16C (P)	20	15	105	75	-	55	16	2	-	4-14	25	115	85	-	65	16	2	-	4-14	110	95	378
	25	16	115	85	-	65	16	2	-	4-14	32	140	100	-	78	18	2	-	4-18	110	95	378
	32	20	140	100	-	78	18	2	-	4-18	40	150	110	-	85	18	3	-	4-18	115	100	378
	40	25	150	110	-	85	18	3	-	4-18	50	165	125	-	100	20	3	-	4-18	120	110	406
	50	32	165	125	-	100	20	3	-	4-18	65	185	145	-	120	20	3	-	4-18	135	120	450
	65	40	185	145	-	120	20	3	-	4-18	80	200	160	-	135	20	3	-	8-18	160	140	520
	80	50	200	160	-	135	20	3	-	8-18	100	220	180	-	155	22	3	-	8-18	170	135	525
	100	65	220	180	-	155	22	3	-	8-18	125	250	210	-	185	22	3	-	8-18	195	175	690
	125	80	250	210	-	185	22	3	-	8-18	150	285	240	-	210	24	3	-	8-23	210	190	780
	150	100	285	240	-	210	24	3	-	8-23	175	310	270	-	240	26	3	-	8-23	255	230	838
	200	125	340	295	-	265	26	3	-	12-23	250	405	355	-	320	30	3	-	12-26	300	260	992
	250	150	405	355	-	320	30	3	-	12-26	300	460	410	-	375	30	4	-	12-26	350	320	1266
	300	220	460	410	-	375	30	4	-	12-26	400	580	525	-	485	36	4	-	16-30	370	350	1283
	350	250	520	470	-	435	34	4	-	16-26	500	715	650	-	608	44	4	-	20-34	500	450	1520
	400	280	580	525	-	485	36	4	-	16-30	500	715	650	-	608	44	4	-	20-34	500	450	1530
A42Y 25C A42Y-25P A42Y-25R KA42Y-25C DA42Y-25 (P)	20	15	105	75	-	55	16	2	-	4-14	25	115	85	-	65	16	2	-	4-14	110	95	378
	25	16	115	85	-	65	16	2	-	4-14	32	140	100	-	78	18	2	-	4-18	110	95	378
	32	20	140	100	-	78	18	2	-	4-18	40	150	110	-	85	18	3	-	4-18	115	100	378
	40	25	150	110	-	85	18	3	-	4-18	50	165	125	-	100	20	3	-	4-18	120	110	406
	50	32	165	125	-	100	20	3	-	4-18	65	185	145	-	120	20	3	-	4-18	135	120	450
	65	40	185	145	-	120	22	3	-	8-18	80	200	160	-	135	20	3	-	8-18	160	140	520
	80	50	200	160	-	135	24	3	-	8-18	100	220	180	-	155	22	3	-	8-18	170	135	525
	100	65	230	190	-	160	24	3	-	8-23	125	250	210	-	185	22	3	-	8-18	195	175	690
	125	80	270	220	-	188	28	3	-	8-26	150	285	240	-	210	24	3	-	8-23	210	190	780
	150	100	300	250	-	218	30	3	-	8-26	175	310	270	-	240	26	3	-	8-23	255	230	838
	200	125	360	310	-	278	34	3	-	12-26	250	405	355	-	320	30	3	-	12-26	300	260	992
	250	150	425	370	-	332	36	3	-	12-30	300	460	410	-	375	30	4	-	12-26	350	320	1266
300	220	485	430	-	390	40	4	-	16-30	400	580	525	-	485	36	4	-	16-30	370	350	1283	
A42Y-40 A42Y-40P A42Y-40R KA42Y-40 DA42Y-40P	20	15	105	75	51	55	16	2	4	4-14	25	115	85	-	65	16	2	-	4-14	100	95	378
	25	16	115	85	58	65	16	2	4	4-14	32	140	100	-	78	18	2	-	4-18	100	95	378
	32	20	140	100	66	78	18	2	4	4-18	40	150	110	-	85	18	3	-	4-18	115	100	378
	40	25	150	110	76	85	18	3	4	4-18	50	165	125	-	100	20	3	-	4-18	120	110	406
	50	32	165	125	88	100	20	3	4	4-18	65	185	145	-	120	20	3	-	4-18	135	120	450
	65	40	185	145	110	120	22	3	4	8-18	80	200	160	-	135	20	3	-	8-18	160	140	520
	80	50	200	160	121	135	22	3	4	8-18	100	220	180	-	155	22	3	-	8-18	170	135	525
	100	65	235	190	150	160	24	3	4.5	8-23	125	250	210	-	185	22	3	-	8-18	195	175	690
	125	80	270	220	176	188	28	3	4.5	8-26	150	285	240	-	210	24	3	-	8-23	210	190	780
	150	100	300	250	204	218	30	3	4.5	8-26	200	340	295	-	240	26	3	-	8-23	255	230	838
	200	125	375	320	260	282	38	3	4.5	12-30	250	405	355	-	320	30	3	-	12-26	300	260	992
	250	150	450	385	313	345	42	3	4.5	12-34	300	460	410	-	375	30	4	-	12-26	350	320	1266

* 内容仅供参考，更多需求请联系我们。

主要外形尺寸 /

型号	DN	D0	D	K	g	g1	b	f	f1	Z- Φ _d	DN'	D 1	k1	g3	g2	b1	f'	f1'	Z1- Φ _{d1}	L	L1	H
A42Y-64 A42Y-64P A42Y-64R DA42Y-64(P)	20	10	125	90	51	68	22	2	4	4-18	25	115	85	58	65	16	2	4	4-14	96	85	264
	25	15	140	100	58	78	22	2	4	4-18	32	180	100	66	78	18	2	4	4-18	110	100	277
	32	20	155	110	66	82	24	2	4	4-23	40	150	110	76	85	18	2	4	4-18	130	110	289
	40	25	170	125	76	95	24	3	4	4-23	50	165	125	88	100	20	3	4	4-18	130	120	319
	50	32	180	135	88	105	26	3	4	4-23	65	185	145	110	120	22	3	4	8-18	135	130	389
	65	40	205	160	110	130	28	3	4	8-23	80	200	160	121	135	22	3	4	8-18	175	160	493
	80	50	215	170	121	140	30	3	4	8-23	100	235	190	150	160	24	3	4.5	8-23	175	160	483
	100	65	250	200	150	168	32	3	4.5	8-26	125	270	220	176	188	28	3	4.5	8-25	195	195	613
	150	100	345	280	204	240	38	3	4.5	8-34	200	375	320	260	282	38	3	4.5	12-30	280	265	894
A42Y-100 A42Y-100P A42Y-100R DA42Y- 100(P)	20	10	125	90	51	68	22	2	4	4-18	25	115	85	58	65	16	2	4	4-14	96	85	264
	25	16	140	100	58	78	24	2	4	4-18	32	140	100	66	78	18	2	4	4-18	110	100	277
	32	20	155	110	66	82	24	2	4	4-23	40	150	110	76	85	18	2	4	4-18	130	110	289
	40	25	170	125	76	95	26	3	4	4-23	50	165	125	88	100	20	3	4	4-18	130	120	319
	50	32	195	145	88	112	28	3	4	4-26	65	185	145	110	120	22	3	4	8-18	135	130	389
	65	32	220	170	110	138	32	3	4	8-26	80	200	160	121	135	22	3	4	8-18	175	160	493
	80	40	230	180	121	148	34	3	4	8-26	100	235	190	150	160	24	3	4-5	8-23	175	160	483
	100	50	265	210	150	172	38	3	4.5	8-30	125	270	220	176	188	28	3	4.5	8-25	195	195	613
	150	80	355	290	204	250	46	3	4.5	12-34	200	375	320	260	282	38	3	4.5	12-30	280	265	894

* 内容仅供参考，更多需求请联系我们。