

Action code: IMMEDIATELY**Third-party spindle guides and nozzles**

- increased risk of scavenge space fire

SL2020-701/KNB
August 2020**Concerns**Owners and operators of MAN B&W two-stroke marine diesel engines.
Type: MC/MC-C and ME/ME-C**Summary**

The use of third-party spindle guides and nozzles endangers the operation of the main engine and increases the risk of engine breakdown and scavenge space fire. We recommend using only OEM parts.

Dear Sir or Madam

We have received service reports describing breakdown cases caused by sub-standard spindle guides. It is therefore necessary to emphasise the high risk involved in using spindle guides from third-party sources in fuel valves for engines designed by MAN Energy Solutions. Such cases could pose serious potential threats to property and persons, and may potentially even result in bodily injuries and/or fatal casualties.

We must emphasise that these third-party spindle guides and nozzles are not in accordance with our design or standard and they are not approved by MAN Energy Solutions.

If the nozzle fails it will result in fuel oil not being atomised, in which case an exhaust gas temperature deviation alarm will occur. It is very important to take this alarm seriously and to solve the reason for the alarm immediately, as there is a risk of scavenge space fire due to fuel oil accumulation.

To minimise the risk of the above, we recommend using only original equipment manufacturer (OEM) parts. If you have identified third-party spindle guides and nozzles on your engine or have recently received an order containing such parts, and you need OEM parts instead, then contact PrimeServ at Primeserv-cph@man-es.com for a non-committal quote.

Yours faithfully

**Mikael C Jensen**
Vice President, Engineering**Stig B Jakobsen**
Senior Manager, Operation

Head office (& po. address)
MAN Energy Solutions
Tegholmsholmsgade 41
2450 Copenhagen SV
Denmark
Phone: +45 33 85 11 00
Fax: +45 33 85 10 30
info-cph@man-es.com
www.man-es.com

PrimeServ
Tegholmsholmsgade 41
2450 Copenhagen SV
Denmark
Phone: +45 33 85 11 00
Fax: +45 33 85 10 49
Primeserv-cph@man-es.com

Production
Tegholmsholmsgade 35
2450 Copenhagen SV
Denmark
Phone: +45 33 85 11 00
Fax: +45 33 85 10 17
manufacturing-dk@man-es.com

Forwarding & Receiving
Tegholmsholmsgade 35
2450 Copenhagen SV
Denmark
Phone: +45 33 85 11 00
Fax: +45 33 85 10 16
shipping-cph@man-es.com

MAN Energy Solutions
Branch of MAN Energy Solutions
SE, Germany
CVR No.: 31611792
Head office: Tegholmsholmsgade 41
2450 Copenhagen SV, Denmark
German Reg.No.: HRB 22056
Amtsgericht Augsburg

The specific third-party spindle guides and nozzles have no marking from the maker and are of dubious quality and design. The only marking found is the IMO required marking of the nozzle.

As Fig. 1 shows, the nozzle is made of three individual parts pressed together.

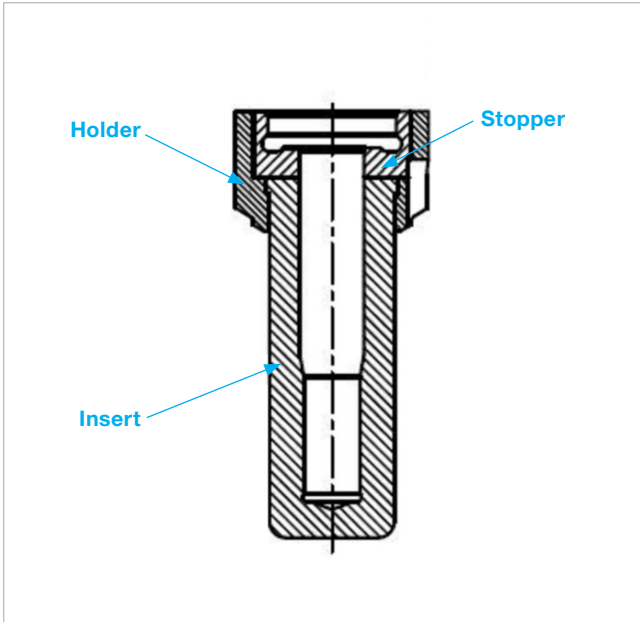

Fig. 1: Assembly sketch of nozzle made of three parts pressed together

As the service reports show, this design is far from being sufficiently robust and the complete tip of the nozzle may disintegrate from the fuel valve, see Fig. 2.



Fig. 2 Close-up of the damaged nozzle

We cannot emphasise strongly enough that the use of third-party spindle guides endangers the service of the main engine. It will increase the risk of engine breakdown and premature stoppage to exchange parts, and it will most likely influence the reliability of the main engine.

We recommend the ship crew to check their orders and spare parts for third-party spindle guides immediately and to remove any dubious spindle guides. It is necessary to remove the nozzle from the spindle guide and inspect the internal boring to identify third-party nozzles, see Fig. 3.

If you have any technical questions or inquiries regarding this Service Letter, contact our Operation Department at Operation2S@man-es.com

If you wish to request a quotation or order OEM spindle guides and nozzles, contact PrimeServ at Primeserv-cph@man-es.com

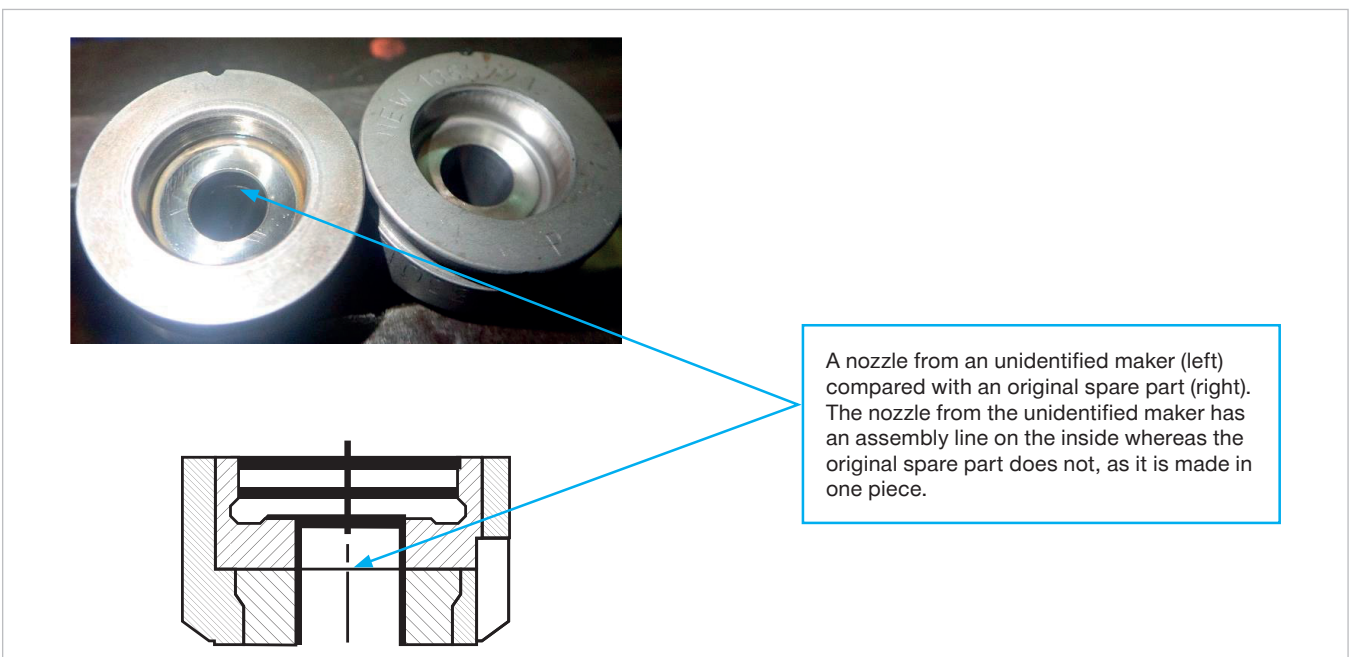

Fig. 3: How to identify third-party nozzles